

HARDWARE:

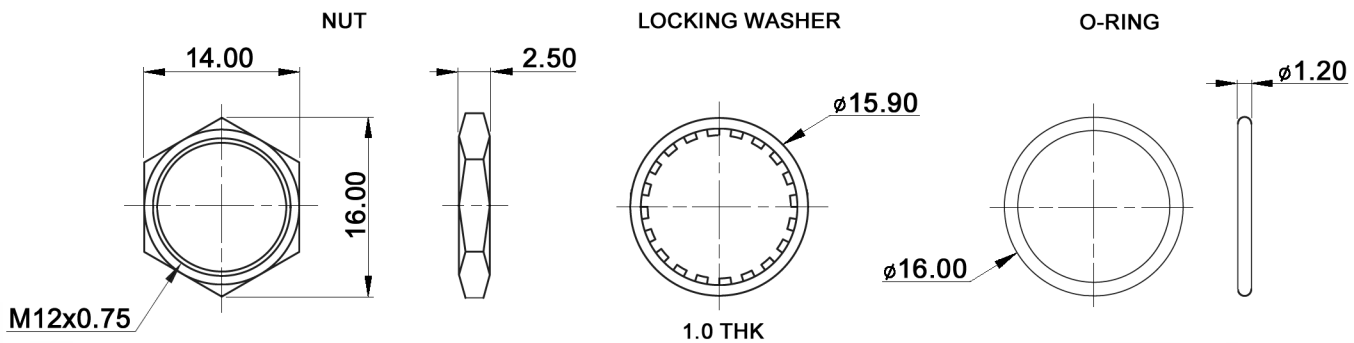

Compliance: RohS III (2015/863/EU)

Tolerances: 0.00: ±0.25mm 0.0: ±0.40mm	Date	Name
	03/09	dr
Accessory	10/19	dr
Rating, electrical life	02/13	dr
Dimensions	06/10	dr
Modifications	Date	Name

DPW 1 AG-x

knitter-switch

30 17 62

Page

1/2

Specifications:

Contact rating: max. 100mA, 24V DC - endurance 200 000 cycles
 max. 2A, 125VAC - endurance 10 000 cycles
 Contact resistance: 100mOhm max.
 Insulation resistance: 1GOhm min. at 500V DC
 Dielectric strength: 1 000V AC RMS
 Operating force: 4.5 - 6.5N
 Torque: 1.5Nm max. applied to nut
 Soldering conditions: 350°C max., 5sec.
 Panel thickness: min.: 1.5mm; max.: 4.0mm
 Total travel: 2.5mm
 Switching function: off - on
 Contact bounce: 10ms
 Material: Case / cap / bushing: polyamide 6/6
 Terminal / contact: gold over silver plated
 IP rating: IP 67 (mounted)

X=CAP COLOR	
W	white
K	black
R	red
O	orange
Y	yellow
G	green
B	blue

Compliance: RohS III (2015/863/EU)

Tolerances: 0.00: ±0.25mm 0.0: ±0.40mm		Date	Name	<h1>DPW 1 AG-x</h1>	
		03/09	dr		
Accessory	10/19	dr	<h2>30 17 62</h2>	Page	
Rating, electrical life	02/13	dr		knitter-switch	2/2
Dimensions	06/10	dr			
Modifications	Date	Name			